

FITTING INSTRUCTIONS

Thank you for choosing a Newtronic Contactless optical ignition system.

1. First read the fitting instructions all the way through and familiarise yourself with the parts provided in the fitting kit with the help of the explanatory diagram.
2. Disconnect battery earth, remove cover over contact breakers, remove also the casting covering the timing marks.
3. Raise seat and remove petrol tank.
4. Disconnect the point wires from the bullet connectors where they enter the main harness (blue, 1 yellow). Disconnect also the condensers.
5. Undo the screws securing the points baseplate and remove.
6. Undo the 10mm bolt securing the auto-advance mechanism and remove. The point cam must also be removed from the auto advance itself, this is simply pulled off.
7. Turn the engine by means of the kickstart (or 14mm spanner on the end of the crankshaft) until the firing mark of the right hand cylinder (F) is aligned with the timing pointer. Ensure also that the drive pin for the auto advance is in the position shown in the diagram.
8. The next step involves the assembly of the Newtronic timing rotor to the auto advance mechanism. These instructions must be followed carefully. Hold the auto advance and feed the Newtronic assembly (rotor and baseplate as supplied) down the shaft of the auto advance mechanism to engage the slots in the lugs of the bob-weights. This must be done in the relationship as shown in the diagram.
9. Fit the assembly back to the bike ensuring the drive for the auto advance is engaged in the camshaft and secure with the 10mm bolt.
10. Check the engine is still in the F timing mark and align the Newtronic baseplate so as to be in the position shown in the diagrams. The trailing edge of the rotor should be central in the fixed lamphousing. Temporarily secure with the two Phillips screws and washers fitting the cable clip for the trigger lead under the lower screw.
11. Route the Newtronic trigger lead using the original clips to appear under O/S side cover. Connect the trigger lead to the Newtronic switching unit using the moulded plug cover and fill with the sealant provided. Secure the plug with the two self tapping screws. See diagram.
12. Thread the three wires from the Newtronic unit along the frame top rail to the coils. Connect the blue and yellow wires in the bullet connectors from which the original point wires were removed, ensuring correct colour coding blue to blue, yellow to yellow. Connect the black/white to the coil feed as

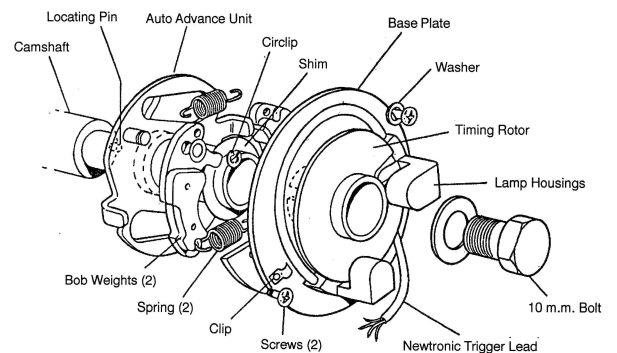
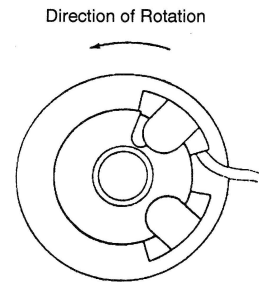

**EXPLODED VIEW OF IGNITION
TIMING ASSEMBLY**

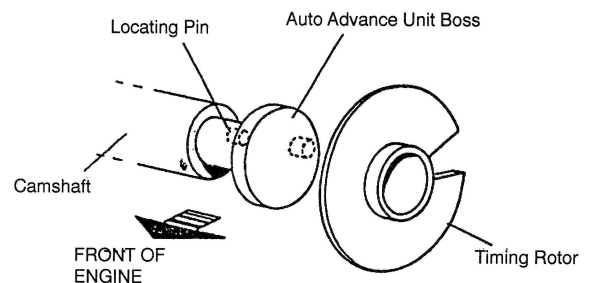

**RELATIVE POSITIONS OF ROTOR AND
CAMSHAFT ON ASSEMBLY**

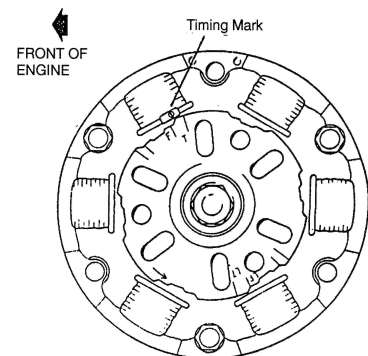

MOTORCYCLE IGNITION SYSTEM - HO5

Honda CB250 G5

shown in the diagram. This is the 12V feed for the Newtronic, do not disconnect the original coil feed.

13. Earth the blue lead to the battery negative terminal. The original coil feed.
14. Wipe clean the side of air filter box, remove the protective back from the self- adhesive panel on the back of the Newtronic switching unit and fit to the air box. Ensure it doesn't foul when the side cover is refitted.
15. Replace petrol tank, reconnect battery earth.

All the necessary components are now fitted and it only remains to set the ignition timing. This should NOT be done in bright sunlight or the timing will be affected. Setting the ignition timing is basically no different to the procedure adopted when using contact breakers, except that a stroboscope timing light must be used. It should be remembered that the engine fires as the timing rotor leaves the lamp housing. You must ensure that the rotor does not foul the lamp housings.

To set the ignition timing proceed as follows:

1. Connect the timing light to the R/H cylinder and start the engine. Align the F with the pointer by rotating the whole Newtronic baseplate. Also ensure the advance marks are correctly aligned by revving the engine and checking with the stroboscope.
2. Connect the timing light to UH cylinder and adjust by moving the small adjustable lamp housing.
3. Check all screws are tight and refit the cover and gasket over the points, and the cover over the timing marks.

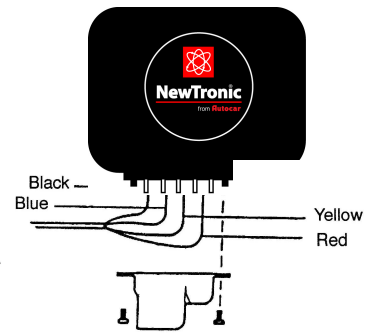

TRIGGER LEAD CONNECTIONS TO SWITCHING UNIT AND PLUG ASSEMBLY

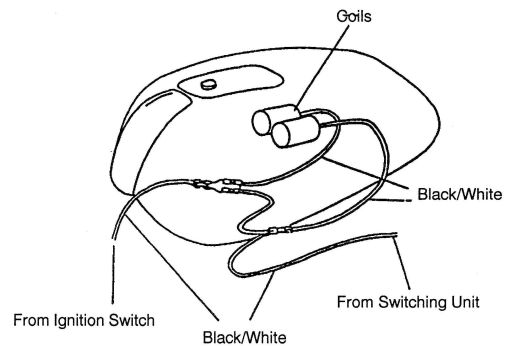

WIRING CONNECTIONS UNDER TANK

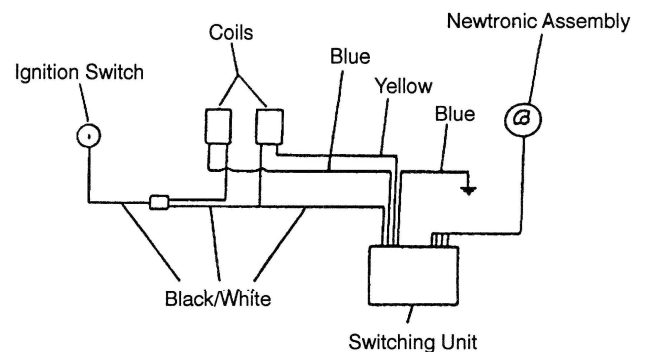

SCHEMATIC WIRING DIAGRAM



Autocar Electrical Equipment Co. Ltd.

49/51 Tiverton Street, London SE1 6NZ Tel: 020 7403 4334